

selected works

2011-2024

This portfolio presents my work in the area of product design. It will showcase selected examples, without going into full details in order to limit the scope. All the pictures or works are done by myself unless stated otherwise. If further information is requested or needed, please feel free to get in touch:

Ruben Borer
ruben.borer@hotmail.com
+41 79 223 77 87

education

2005-2009
Regionales Gymnasium
Laufental-Thierstein, Laufen

2009-2014
Liceo Artistico, Zurich

since 2021
BA Object Design, Lucerne
University of Applied Sciences
and Arts, Emmenbrücke

work

2016
Frontend developer and IT
support, Futuretek, Zurich

2016-2017
Junior Consultant, Factum
Kommunikation, Zurich

2017-2018
Digital Designer, Relate, Zurich

since 2018
Self-employed,
Atelier Rubinzki, Zurich



Taoism sees men's noblest duty - despite all the possibilities that are available to us - in the choice of not doing a thing.

This thought has accompanied me in my work ever since. It's been changing my design attitude over the years and deepened my appreciation of resources even more. The environment and we as craftsmen spend a lot of time in order to provide for them. Understanding this, for me it's become very important to conserve as much as possible, by reducing consumption and production. So I will always prefer not to build something, unless I have good reasons to do so.

When designing and building objects I want to make sure to use as few resources as possible. This is why I prefer to work with throw-away and waste materials, reusing leftovers of all kinds, repairing instead of building from scratch and gathering instead of selecting - always bearing in mind that the choice of the material is very crucial too. The stronger a material suits its purpose the longer I can make it last fulfilling its function. This will result in conserving resources in the future. Something that seems sustainable today might not always stand the test of time and therefore not be a good choice for long term use.

All these rules enriched my work more than it hindered me, as I was forced to take new paths and find new solutions.

code of conduct

concepts
designs
products

S'SEL

AI-designed lounge chair



specifications

year	2023
material	walnut/cherry
fabric	linen
height	127 cm
width	85 cm
depth	95 cm
co-creator	Leonardo AI

description

In a world of fleeting trends, this Japanese wood joint inspired chair stands as a timeless testament to exquisite craftsmanship and unparalleled design. Crafted with precision and a deep respect for tradition, this chair offers a sense of authenticity that transcends the ordinary.

(written by ChatGPT)

work

commanding Leonardo AI to design a lounge chair with different prompts until satisfied with the result, let ChatGPT write about it, then build functional version of it in Rhino, to later feed renderings of the reconstruction back to Leonardo AI to make it look prettier - this will cost my job

¹ KeyShot rendering of my reconstruction, fed to Leonardo AI through image to image generation then retouched with Photoshop
² Leonardo AI's design for the prompt: *japanese wood joint, dark wooden simple chair with cotton strap weaving seating surface, white background product shot*



Its elegant, dark wooden frame is a sight to behold, showcasing the rich hues of natural wood that exude warmth and sophistication. The design is a beautiful homage to Japanese joinery techniques, reflecting the meticulous art of wooden construction that has been perfected over centuries.

The seating surface of the chair is featuring a cotton strap weaving that not only provides comfort but also adds a touch of artistry to the chair. The weaving pattern is not only aesthetically pleasing but also durable, ensuring that this chair is not just a piece of furniture but a functional work of art.
(written by ChatGPT)

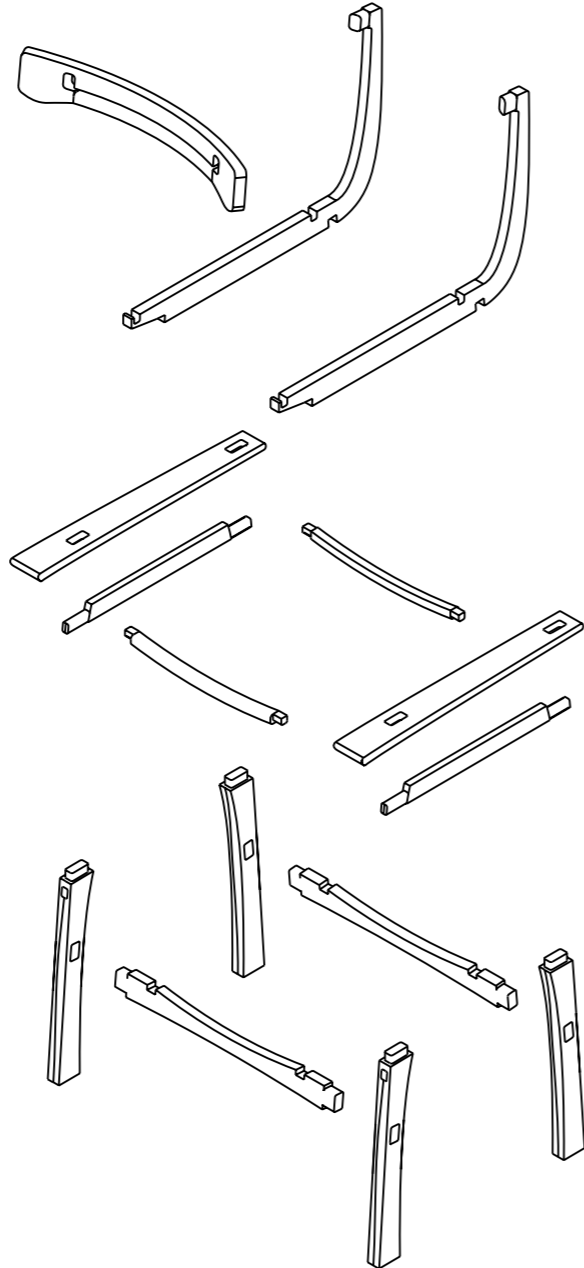
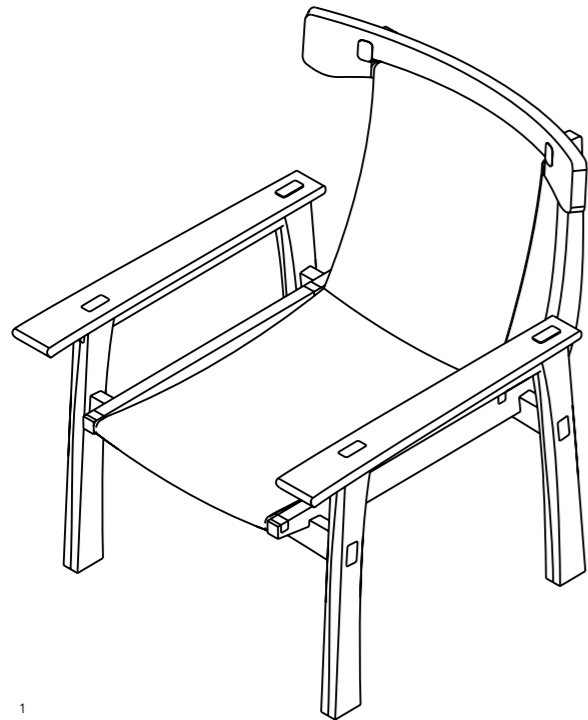

S'SEL

AI-designed lounge chair

- ¹ own deconstruction of the AI's design with ChatGPT description
- ² Leonardo AI chair design for the prompt: *japanese wood joint, dark wooden simple chair with cotton strap weaving seating surface, white background product shot*
- ³ Leonardo AI chair design for the prompt: *japanese wood joint, wooden simple chair with cotton weaving seating surface, white background product shot*
- ³ KeyShot rendering of my Rhino build
- ³ Leonardo AI's close image to image translation, became the final chair
- ³ Leonardo AI's loose image to image translation, became the final scene

traditional cheese cover design



specifications

year	2021
bottom	marple
lid	moulded wood
seam	willow branch core
hardware	stainless steel
height	17 cm
width	23 cm
depth	23 cm

concept

designing a cover for the traditional Tête de Moine cheese made from wood, with focus on simplicity and no use of composites or adhesives

work

cutting the moulded wood, watering, shaping, drilling, splitting a willow branch as a "thread", assembling, milling the base plate from leftover maple wood stock including reworking it beforehand.

¹ finished hood, opened
² conceptual sketches of the idea and implementation with measurements

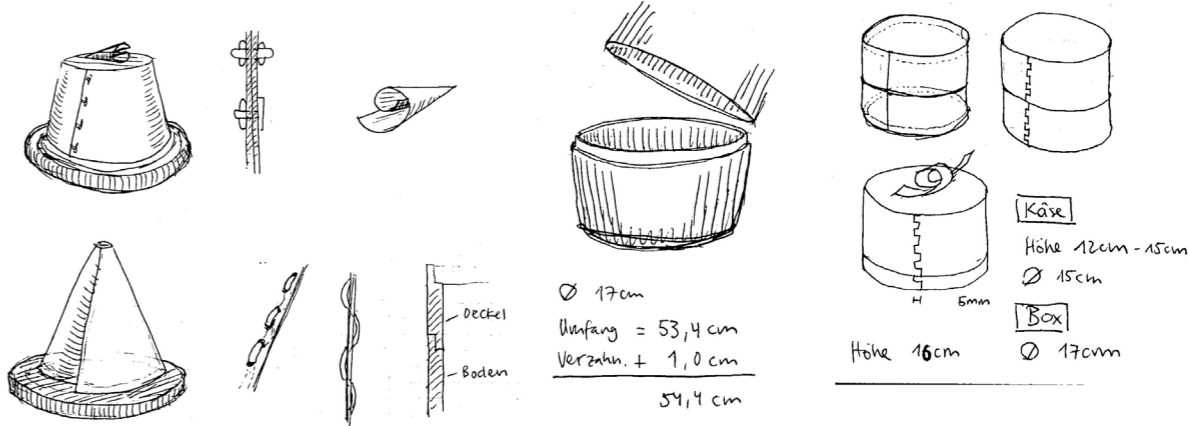

traditional cheese cover design



1

- ¹ cover closed
- ² composition of all variants
- ³ first attempt with interlocking, unfortunately requires glue as it is too thin for a wooden pin hinge
- ⁴ second attempt with dowels, pressed at first but had to be glued after drying due to shrinkage
- ⁵ variation second attempt with overlap
- ⁶ integrated wood defect from the first attempt
- ⁷ third series with deep base rim for better accessibility, base rim glued
- ⁸ third series doweled with deep base rim



3



4



5



6



7



8

Lombal press

production of bookbinding tool



specifications

year	2022
press boards	plywood HPL
stand	MDF
screw clamps	chrome-steel
height	38 cm
width	38 cm
length	19 cm

concept

construction of a Lombal press for DIN A4 portrait and landscape formats landscape formats with small improvements for efficient handling, which I noticed when using another variant

work

cutting the individual parts (preferably from scrap wood), milling the slots for the pins, glueing the parts, welding the pins, attaching the hinges, functional testing

¹ finished lumbeck press for adhesive binding
² wooden claps made of HPL due to resistance to glue residue
³ open slots for the pin holder for quick disassembly and better accessibility to align the paper stack before glueing



paper lamp

handicraft



specifications

year	2022
shade	paper
stand	MDF (residue)
height	24 cm
width	10 cm
length	10 cm

concept

wireless paper lamp with a wooden base made from residue MDF pieces with simple on/off button

work

digital drawing of the model, paper cutting with plotter, laser cutting, assembly and arranging the battery connection wires to power the internal light source

- ¹ finished lamp with paper shade and switch-on button
- ² lit lamp
- ³ laser template for assembly without adhesives

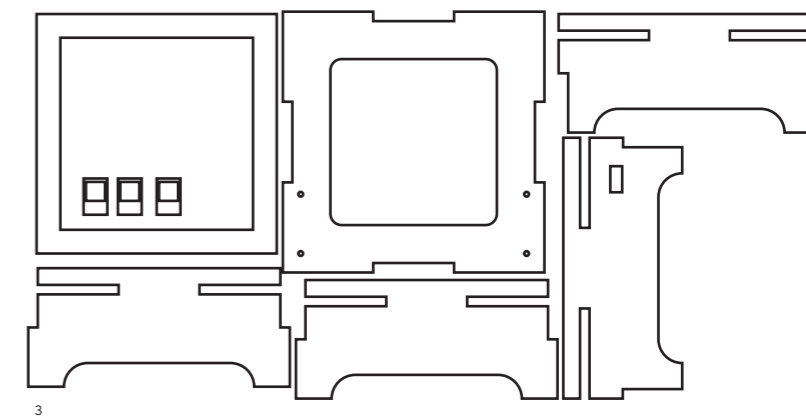

Bonfire

portable LED lamp



specifications

year	2022
lamellas	MDF, plywood
stand	smoked oak (residue), maple (branch piece)
height	22 cm
width	28 cm
length	17 cm

concept

designing and crafting a bespoke mood light for the bathroom with the requirement of integrating second hand glass elements - intended to create a warm light with the shadow cast reminiscent of the vertical beams of a big bonfire

work

light test with different types of glasses, concept, lasering of a lamella cover, construction of a base, soldering of the electronics, painting of the lamellas

¹ finished lamp with base made from a damaged piece of residue smoked oak

² lit lamp with shadow cast, referencing a bonfire

³ prototype of stand for testfitting the glasses and electronics, laser cut plywood



Bonfire

portable LED lamp

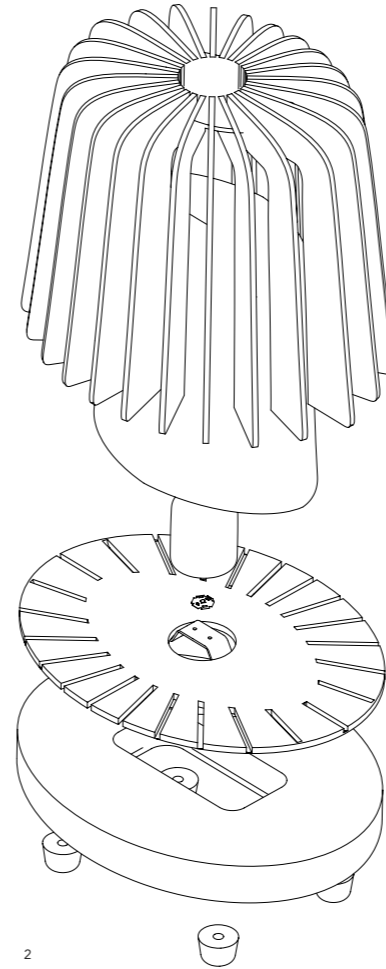

- ¹ lit final version of the lamp in plywood lamellas and maple stand
- ² exploded blueprint of all the parts, missing the battery shield, cables and screws
- ³ originally planned orange lens for warmer light spectrum
- ⁴ finished lamp in bathroom setting, without colored lens



Gosly

product design



specifications

year	2023
wood	various
cord	recycled plastic
height	70 cm
width	50 cm
depth	50 cm

concept

little handmade gift for «Design Schenken» market, designed as keychain, natural fragrance tree (lavender-bee-wax version) or closet-pendant to keep moths away from your fabrics (Swiss stone pine version), made from leftovers except for cord

work

sourcing of material, concept based on found resources to upcycle, wood turning and milling the bodies, design of simple packaging, assembly

¹ Swiss stone pine version, packaged and open, reworked from two pieces of leftover wood

² ensemble of all different bodies after turning them on the lathe and milling the slots and face cutouts



Gosly

product design

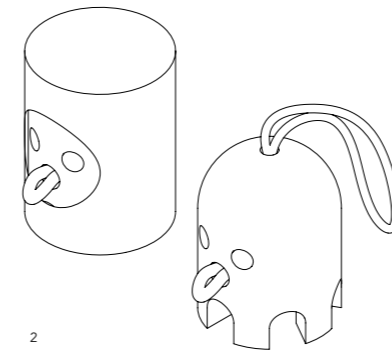

1 detail shot of packaging, laser engraving instead of print, version made from cherry wood leftovers
 2 illustration of first packaging iteration
 3 entire produced batch
 4 all variants of wood, pine, Swiss stone pine, cherry and walnut





Dūne

Brio railway track piece

specifications

year	2022
attachment (dune)	maple
rail track	walnut
height	6 cm
width	32 cm
length	22 cm

concept

special part for the Brio railway track system - concept of an arbitrarily placeable obstacle in the form of a sand dune

This was also my attempt to explore the limits of CNC machining in natural forms.

work

conceptualising ideas, CAD designs, material selection, programming of the milling process, milling on 3-axis CNC, post-processing of the wood.

¹ complete dune attachment for standardized rails (Brio type, with tolerance for other manufacturers)

² systematic models of some other CAD designs for the chosen theme

³ isometric view of final shape, the dune

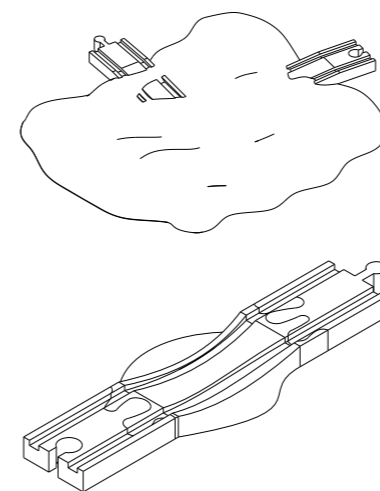

2

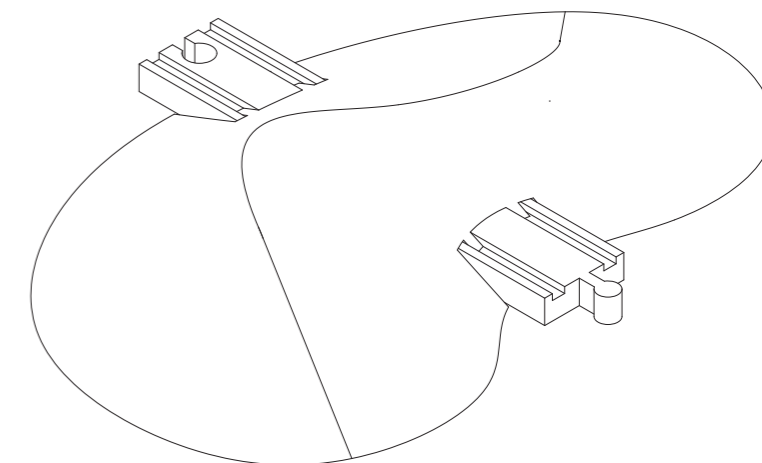

3

Dūne

Brio railway track piece



- ¹ top view of the gradation milling (step two), which follows the topography of the dune like contour lines on a map
- ² clay model of the surface of a flood element
- ³ variants of the dune from the process of form-finding
- ⁴ detail of the transition point into the standard rail
- ⁵ bottom view with a sight of the first milling step (rail profile)

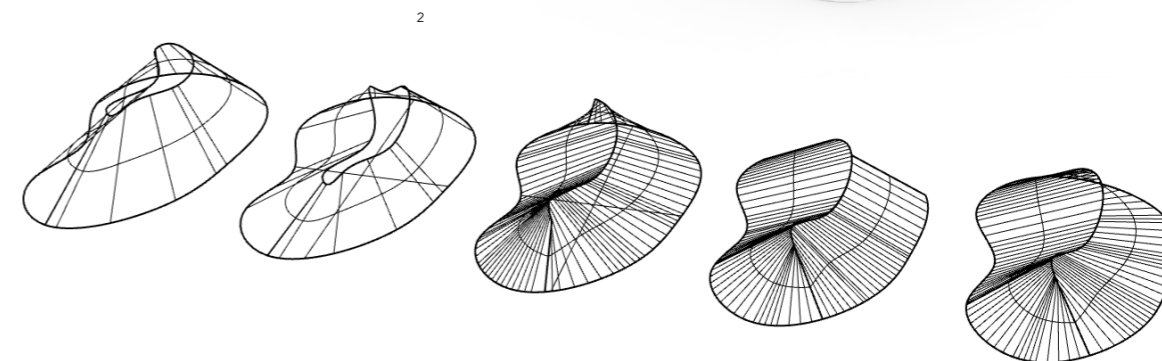

3



just a box

cardboard system



specifications

year	2022
material	cardboard
height	49 cm
width	33 cm
length	22 cm
thickness	5-7 mm

¹ final box with roller blind
² initial CAD drafts created for the construction without external assistive tools

concept

designing furniture from cardboard

In my opinion, cardboard is not suitable for long-term use as a substitute or imitation of another material. My personal goal was to create something out of cardboard that could be used for a longer period of time.

work

concept, CAD drafts, material test, 2D plan creation, plotting, functional tests, improvements

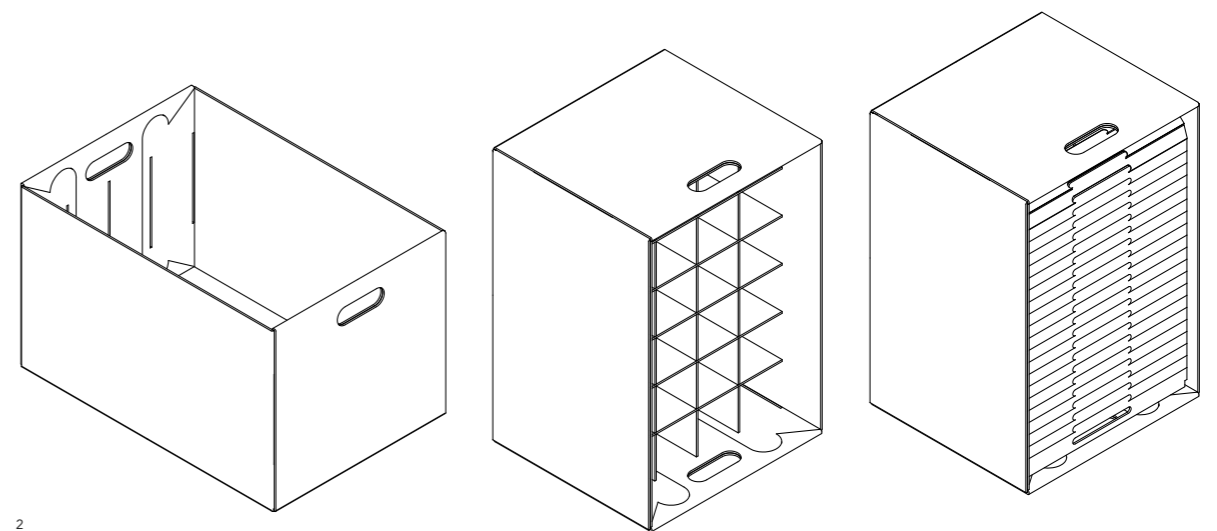

just a box

cardboard system

- ¹ modular plug-in system for precise subdivision and storage of the stored goods
- ² exploded-view illustration of the box with all parts - the final system is based on the fact that smaller offcuts can be used and not everything has to be made from one large piece
- ³ back of box with original print from manufacturer
- ⁴ first test model, folded from larger piece
- ⁵ model to test how to join separate pieces

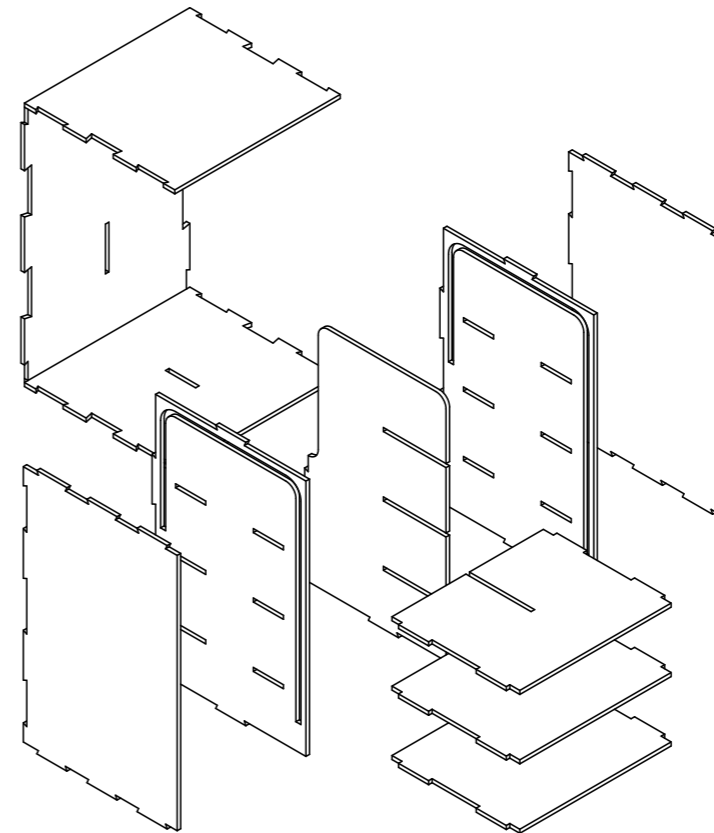

2

4



3

5

traces of time

ceramic memento mori



specifications

year	2021
object	stoneware
glaze	white porcelain glaze
height	10 cm
width	8 cm
length	10 cm

concept

the ultimate trace of time is death, depicted in this object by a skull - deliberately playing with the contrast between the beauty of such a ceramic piece and the seriousness of the subject

work

hand-moulding the skull, followed by the meticulous processes of firing and glazing, moulding with plaster for subsequent recasting in cast porcelain

¹ fully fired and glazed skull

² porcelain cast series in various stages of drying and processing



traces of time

ceramic memento mori



- ¹ original piece in stoneware clay, glazed and fired
- ² post-processed porcelain skull, bone-dry greenware
- ³ porcelain skull with seams from casting, bone-dry greenware
- ⁴ post-processed porcelain skull, leather-hard greenware
- ⁵ roughly improved porcelain skull, leather-hard greenware



traces of time

ceramic memento mori



- ¹ low-tech casting apparatus with feed system to prevent shrinkage
- ² freshly demoulded skull with sprue
- ³ porcelain skulls in various stages of drying and processing
- ⁴ glazed original skull during the moulding process, inlayed in clay
- ⁵ four-part plaster mould



chügelibahn

3D printing



specifications

year 2022
 filaments ABS, HIPS
 dimentions various

concept

designing additional parts for the didactically used marble run from „chügelibahn.ch“ - design of parts that increase the interaction and play experience

work

conceptualising of ideas, CAD designs, test for plug-in parts, 3D printing

- ¹ overview of all printed parts
- ² track for changing the side of the board to be able to insert twice as long marble runs with the same start
- ³ illustration of marble board composition 83 x 83 cm

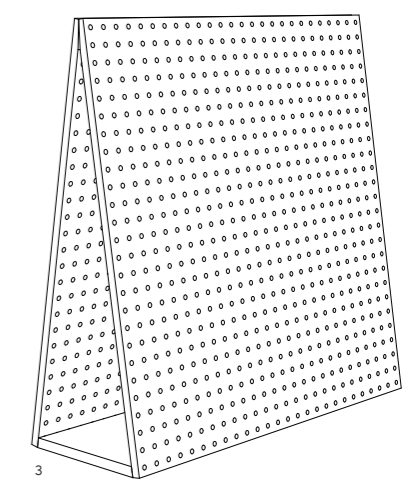
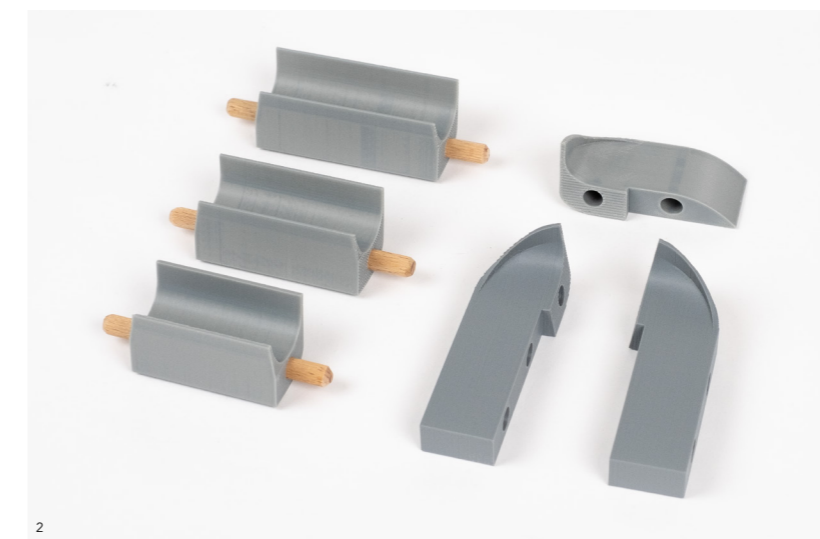

chügelibahn

3D printing

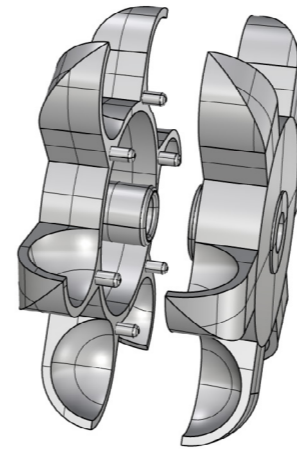
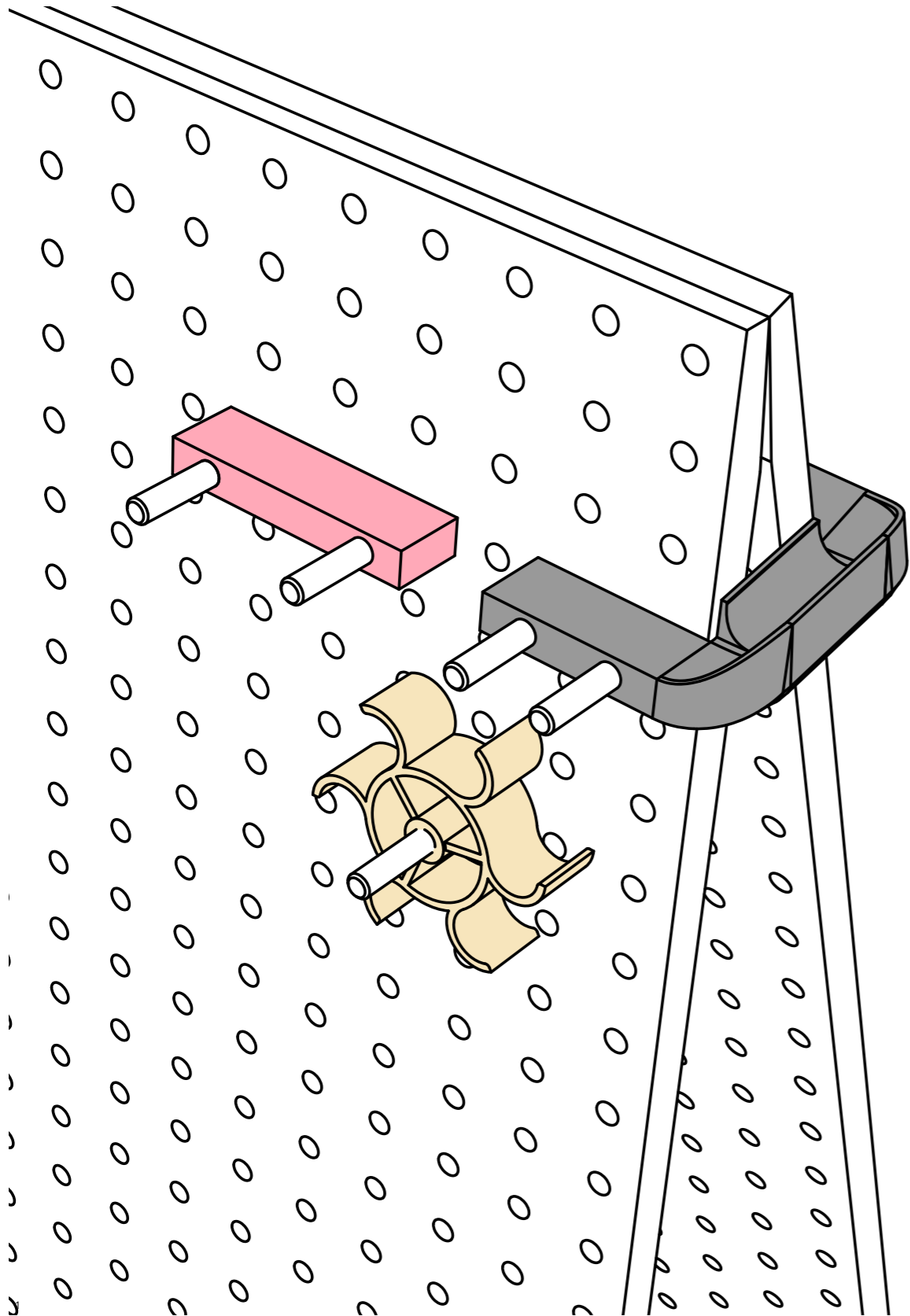

- ¹ finished pieces on the game board
- ² two-part wheel with pins so it can be printed without support structure - saves time and material (sustainability as requirement from client)
- ³ blueprints with dimensions of the first version of the wheel

2

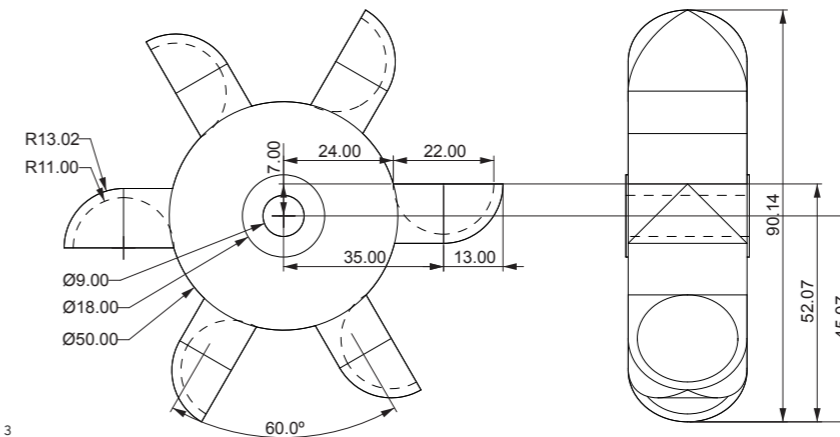
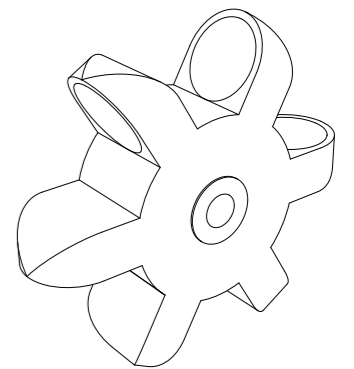
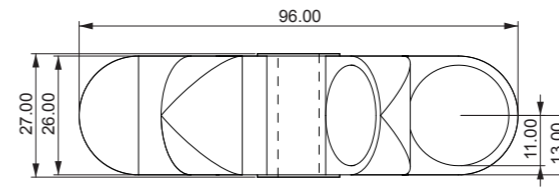

3

chügelibahn.ch	
Mill/Wheel	
version	1
created	14.10.2023
edited	-
format	DIN A4
scale	1:1
unit/tol.	mm
material	PLA or ABS
designer	Ruben Borer



modular wall greening

research

specifications

year 2022
 collaborators Lou Vernier
 Matthia Gagliano

concept

collaborative development of an overall concept for modular facade greening with clay tiles as soil, on which domestic moss species grow - intended to passively help cooling, insulating and noise reduction

work

collecting of moss, pottering brick prototypes, development of a suspension system including a passive irrigation and drainage system, 3D models and visualizations

- ¹ visualization of a possible green space on a building facade
- ² various unfired brick prototypes
- ³ illustration of early model wall with perforated bricks

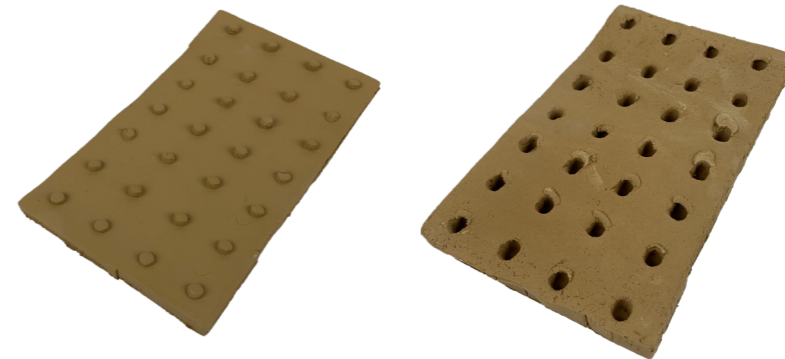

2

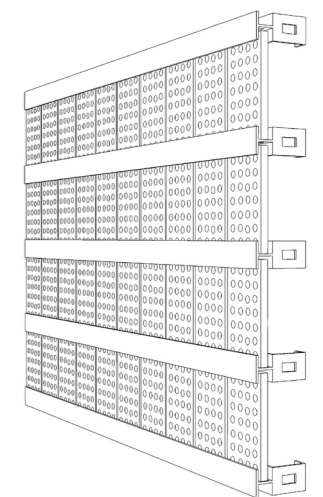

3

modular wall greening

research



- ¹ visualization of possible installations on the building
- ² visualization of possible change over time
- ³ fully ingrown structure
- ⁴ mock-up wall with panel type 1



modular wall greening

research

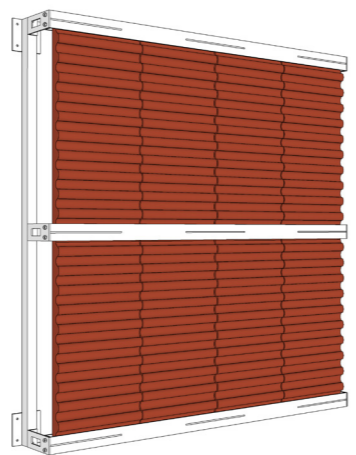
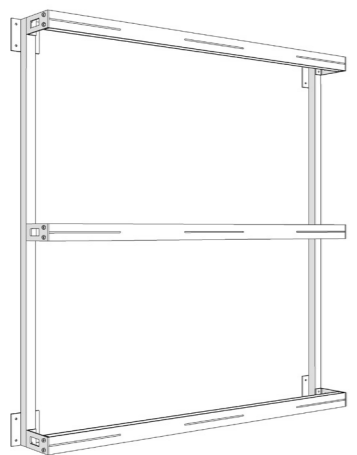
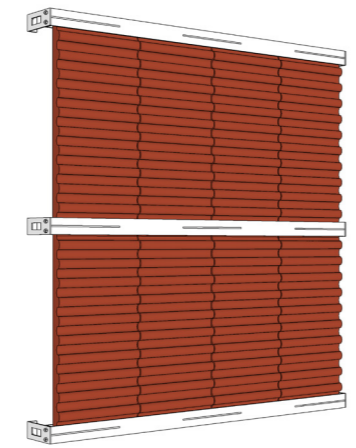
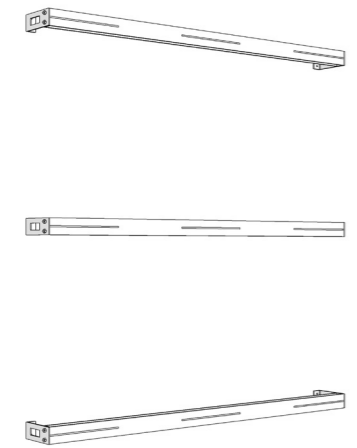
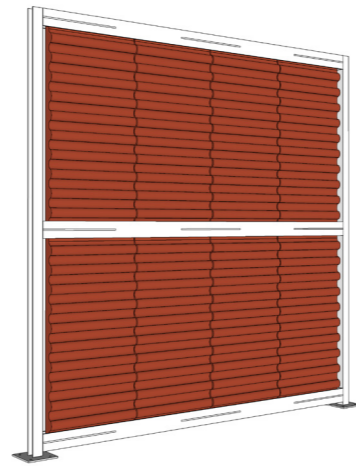
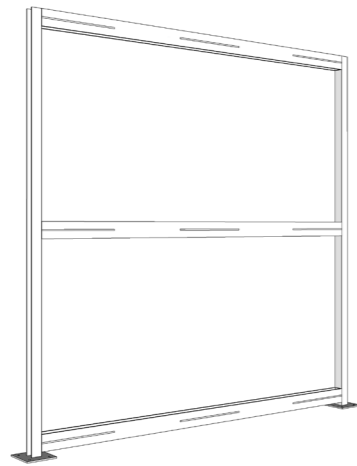

- ¹ different mounting types, based on a few compatible elements
- ² illustration of solution approach for easy opening of the rails from the front
- ³ model of the opening mechanism for functional testing
- ⁴ prototype of the rail on a scale of 1:1, without opening mechanism

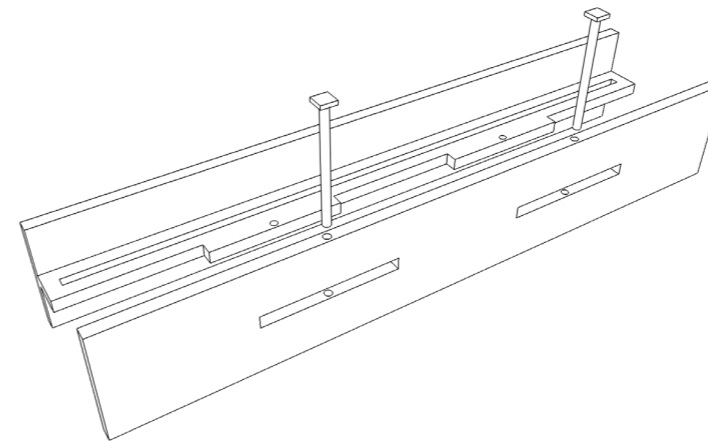

2



3



4

laminar flow faucet

CAD modelling
SLS 3D print, bronze cast



specifications

year	2023
material	bronze
depth	7.2 cm
faucet	4.2 cm
thread & funnel	3 cm
diameter	6.4 cm

concept

designing a fountain faucet with the aim of enhancing the worth of water, which we take for granted

My design tries to illustrate the transformation of water: from wild waves to the most homogenous stream (laminar flow).

work

concept ideation, CAD sketches, test print in nylon, functional test, improvements in CAD, 3D printing, bronze lost-wax casting, post-processing

- ¹ final faucet with laminar water flow
- ² third cast, reworked
- ³ second cast with the sprue structure



laminar flow faucet

CAD modelling
SLS 3D print, bronze cast



- ¹ visualisation of the final faucet over a small sink
- ² oxidation on third casting after overnight stay in warm soapy water
- ³ faulty casting that has discolored in the pickling bath
- ⁴ intermediate status as a visual test
- ⁵ the spray of the waves was carefully lightened with the wire brush



laminar flow faucet

CAD modelling
SLS 3D print, bronze cast

- 1 wax print on rubber base with cuvette for moulding in plaster
- 2 cross-section of the cuvette, left first casting, right second casting
- 3 models for wax printing, both variants
- 4 wax printing directly from the printer with support structure
- 5 processed wax print with additional soldered casting channels

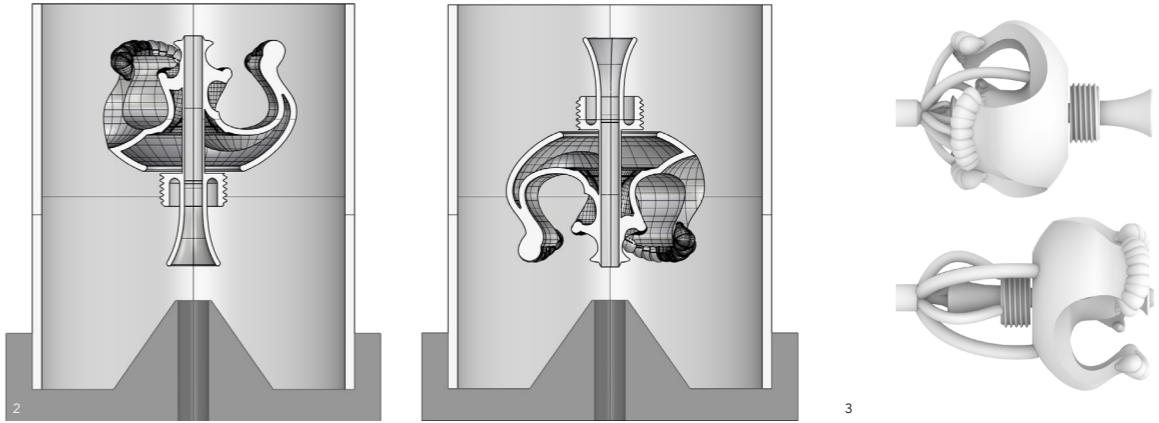

laminar flow faucet

CAD modelling
SLS 3D print, bronze cast



- ¹ first nylon print of the inner nozzle
- ² second nylon print of the inner nozzle with funnel
- ³ functional principle of the inner mould with the aim of reducing water turbulence
- ⁴ cross-section of the inner form variants
- ⁵ flow test used in the pipe
- ⁶ nylon print of final shape for testing before casting

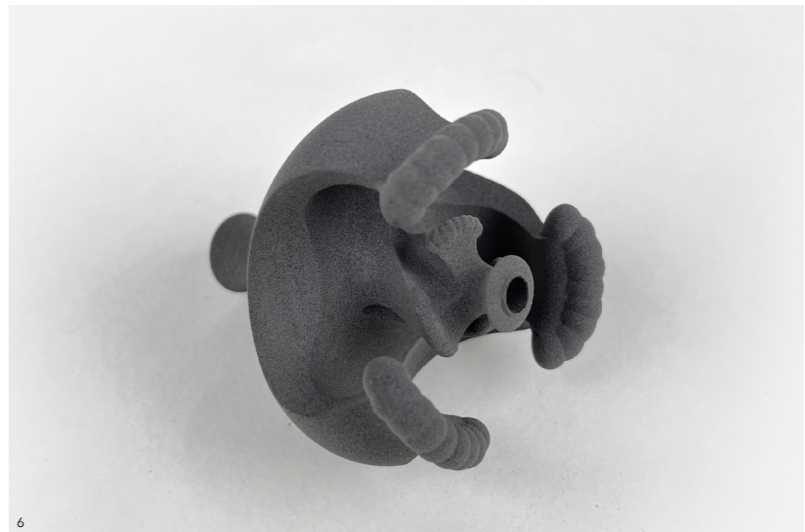
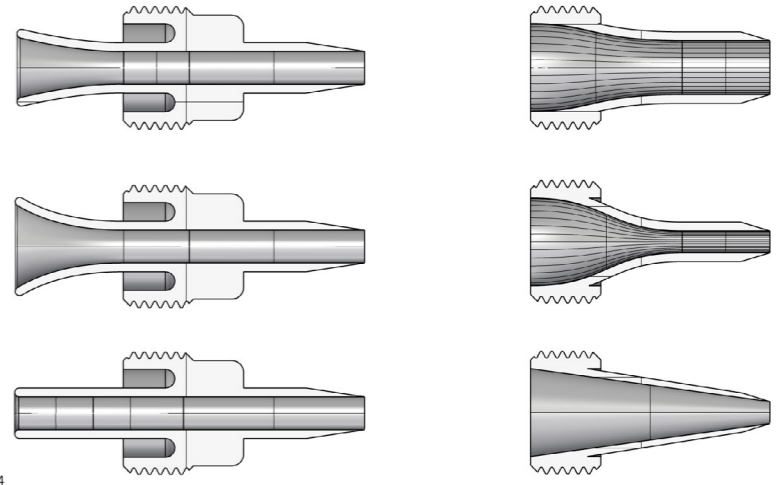
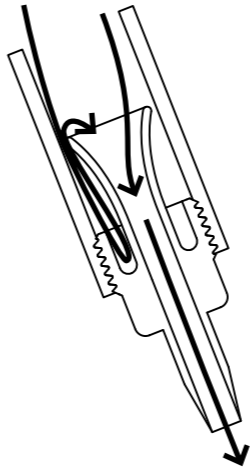

laminar flow faucet

CAD modelling
SLS 3D print, bronze cast

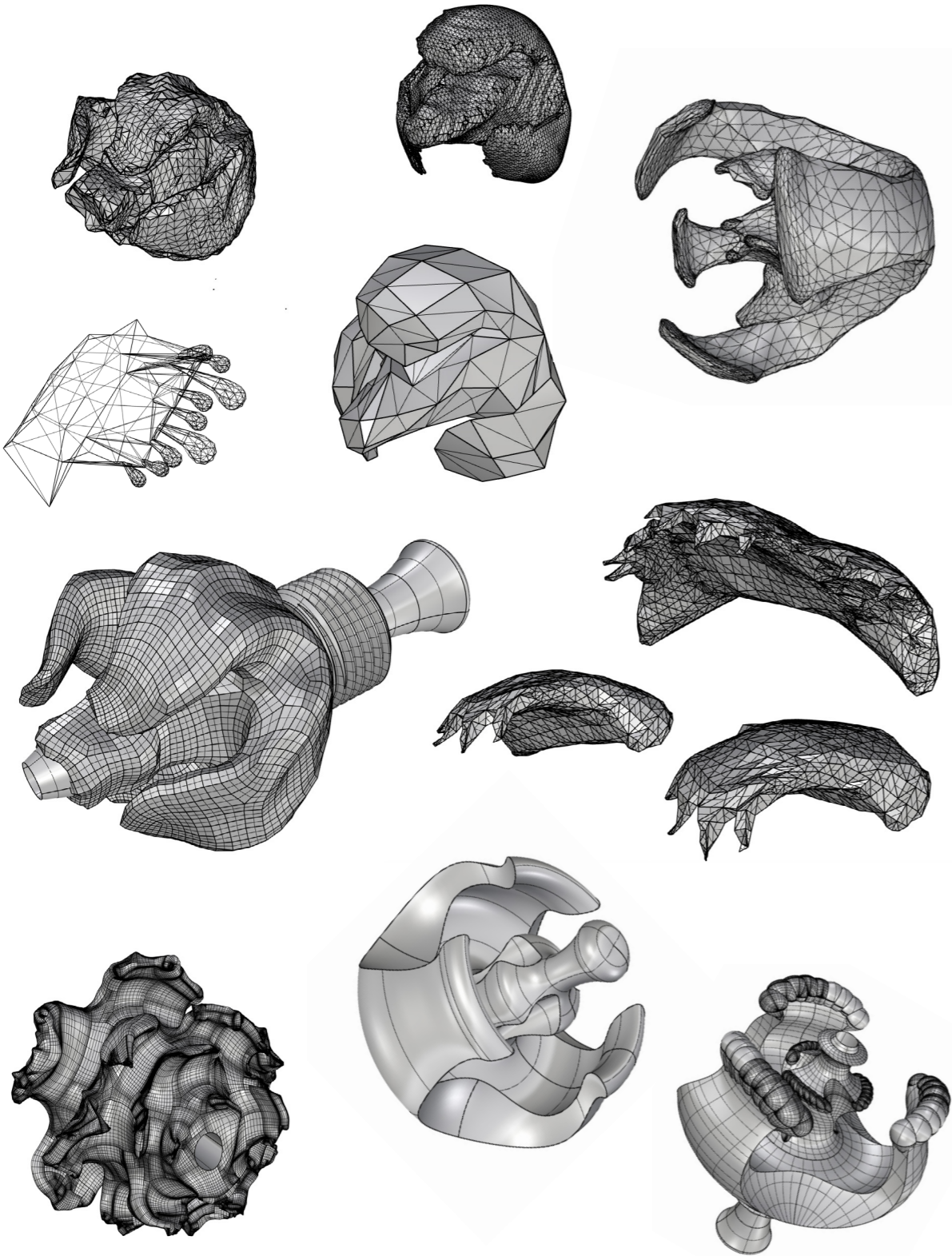

- ¹ some of the 3D models and variations up to the final idea
- ² model of final faucet piece
- ³ 3D scan of hand-moulded clay model, inspiration for final shape
- ⁴ sketch of the desired external shape, based on the models
- ⁵ sketch sequence for isolating the swash shapes of a river

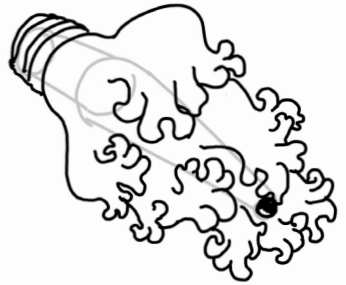
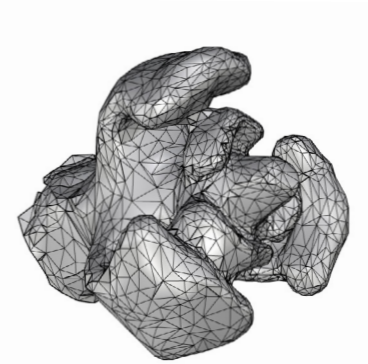

repair
conservation
restoration

camping chair

repair project



specifications

year	2023
frame	steel
upper	tarp
reinforcement	leather
height	80 cm
width	50 cm
length	48 cm
collaborators	Jessica Celis

description

repair of an old camping chair by replacing the broken plastic hardware with jeans leather patches and using a thrown away UBS banner tarp, while preserving its collapsible ability

work

removing broken parts, coming up with new minimal waste cutting pattern, sewing new upper by reusing old linings, sewing matching carrying bag

¹ opened chair with carrying bag

² carrying bag with pull function, made from waste of an failed first cutting pattern



camping chair

repair project

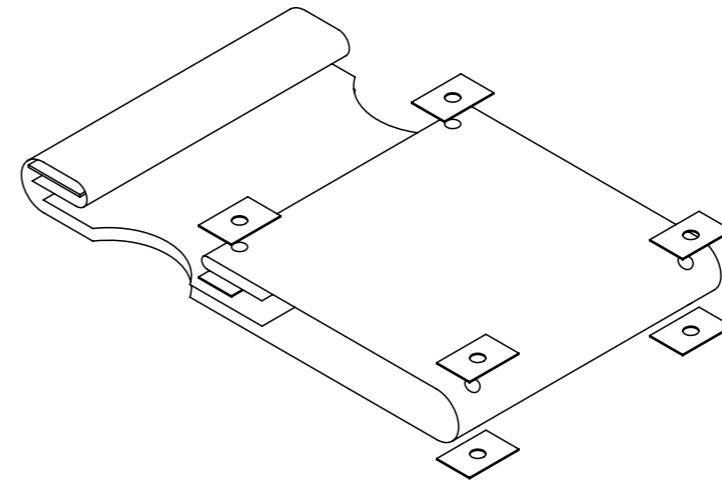

2

- 1 detail shot of the jeans leather patches replacing the broken plastic fittings
- 2 assembly of the upper, tarp all from one piece in order to reduce the seams
- 3 old fabric and broken plastic fittings
- 4 rolled up chair in order to reduce the wear, ready to pack up



4



steel road bikes

repairs and restorations

specifications

year 2014-2020

concept

repairing, conserving or restoring old steel road bikes from the 70s up to the 90s, due to their very durable metal and still mechanic components

work

disassembly, analysis, sourcing of period correct spare parts (where possible), rebuild broken parts, refinish parts, painting, welding, frame corrections, reassembly, technical checkup, mechanical adjustments

¹ refurbished Bianchi Superleggera with hand sewn leather handle bar cover

² refinished and hooded Campagnolo Super Record brake levers

³ refurbished and newly adjusted Campagnolo Super Record rear derailleur

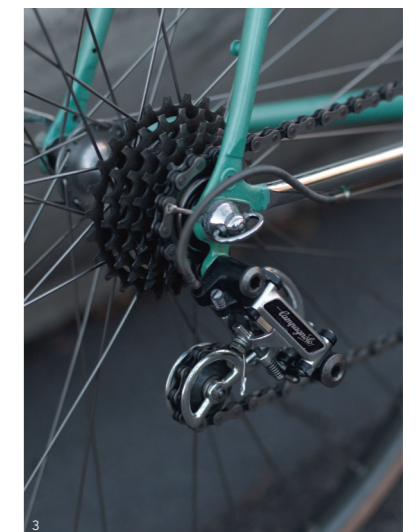
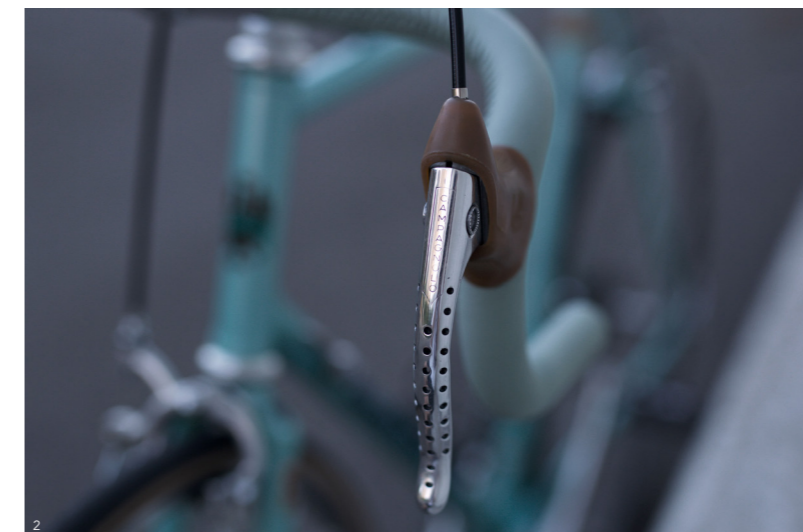

steel road bikes

repairs and restorations

- ¹ restored Colner Gran Sport with hand sewn leather handle bar cover
- ² refurbished Koga Miyata Road Champ with upgraded components
- ³ detail shot of refurbished Campagnolo Gran Sport shift levers and brake calipers
- ⁴ refinished hubs and rims after hand polishing
- ⁵ improvised drilling aid to drill out very common chain ring sizes
- ⁶ refurbished Weros road bike switched to training handle bars





home improvement

repairs and restorations

specifications

year since ever-forever

description

repairing, conserving, restoring or upgrading interiors and furniture

work

disassembly, repair, painting, sewing, welding, refitting, refurbishing, refinishing ... whatever it takes to preserve the object and prolong its life span

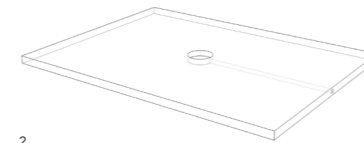

- ¹ painting and upgrading old built-in cupboard with LED lighting system
- ² illustration of drilling schema to accommodate the wiring
- ³ renewing padding on worn out couch
- ⁴ stitching back up the inverted seam from outside

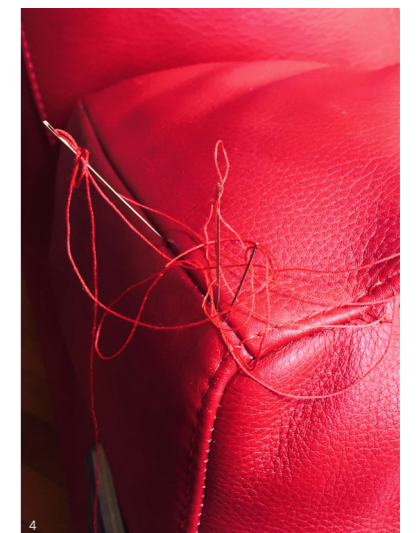



home improvement

repairs and restorations

- ¹ repairing the stand of a friend's old table that was missing pieces
- ² new steel center tube that slides on a square shaft to provide for the missing rigidity
- ³ finished and reassembled table



wooden handle

repair project



specifications

year	2021
handle	walnut
bayonet	steel
strap	rubber from tire
height	3 cm
width	6 cm
length	23 cm

description

repair of an AKM type bakelite bayonet handle with leftover wood while maintaining the functions and appearance

work

removing old shells, creating a template, pre-cutting and milling the handle shells, hollowing out by hand according to the template, fitting, sanding

¹ assembled bayonet

² disassembled bayonet with sheath for use as an insulated cable and wire cutter

³ handle blanks with stencil



2



3

techniques
methods

pottery collection

ceramic art pieces



specifications

year 2019-2021
material ceramics

description

a collection of pottery from my first year of object design showcasing different techniques, often referencing topics such as impermanence, fragility and death in contrast to ceramics image of durability

work

moulding, casting, free throwing on the wheel, trimming, glazing, painting with engobes, firing

¹ still life consisting of ceramic bowls and plaster pistols
² finest details such as lettering and numbers thanks to silicone mould
³ progression of the casts, normal plaster and extra hard model plaster, challenge with viscosity



pottery collection

ceramic art pieces

- ¹ animal shaped vase, stoneware, fired, painted (engobes) and glazed
- ² dual moulded bananas, casted from colored stoneware, and glazed transparently
- ³ leather-hard greenware on pottery wheel
- ⁴ experiment of very fragile work with stoneware
- ⁵ filigrane table cloth concealing another truth



pottery collection

ceramic art pieces

- 1 cast dual moulded stoneware and porcelain bowl
- 2 porcelain thumbing bowl decorated with engobes in the shape of blood drops
- 3 semi serial production of personal dish set made in private
- 4 the final outcome of glazing is very hard to predict sometimes as seen here
- 5 stoneware bowl, turned on the pottery wheel, transparent glaze



tooling

mould making

specifications

year 2021/2022

description

for a lot of form pieces, there is the need to create moulds or other tools to achieve the desired shapes

work

building positives, casting negative moulds from silicone or plaster, building support structures, casting positives from the desired material

¹ finished cast wall hooks

² casting mould with silicone skin and plaster supporting formwork

² foam rubber positives for this casting



tooling

mould making



1

- ¹ composite tests with different fibres like carbon, flax, plastic and glass fibre fabrics
- ² plaster negativ-mould for casting
- ³ hand-held perforating tool for long clay plates built from a rolling pin
- ⁴ two-piece, milled and pinned SIKA moulds
- ⁵ positive from flexible epoxy resin, better to unmoulding
- ⁶ silicone casting mould with MDF support structure



2



3



4



5



6

constructions

model building



specifications

year 2016–2021

description

a selection of works from years of model and prototype building

work

wood work, laser cutting, turning on the lathe, sculpting, sewing, 3D printing, moulding, casting, bracing, welding

¹ grey board model of a chair, deconstructable, 1:5

² quick remodeling of a branch to later cast in wax



constructions

model building

- ¹ early model of a J-Class sailboat, hybrid with traditional hull and modern rig, 1:50
- ² early commission for a model of a kids playground, consisting of scandinavian themed modules, 1:50
- ³ the playground placed inside the structure of the mall
- ⁴ detail shot from above, hinting at the connecting bridges and slide
- ⁵ wooden model of a Weidling type boat, 1:10
- ⁶ 3D printed model of the same Weidling with wooden interior, 1:50

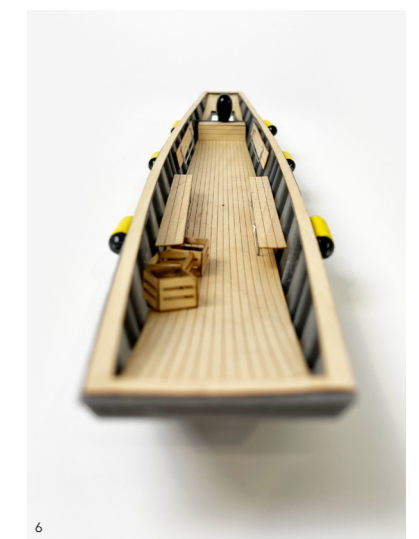
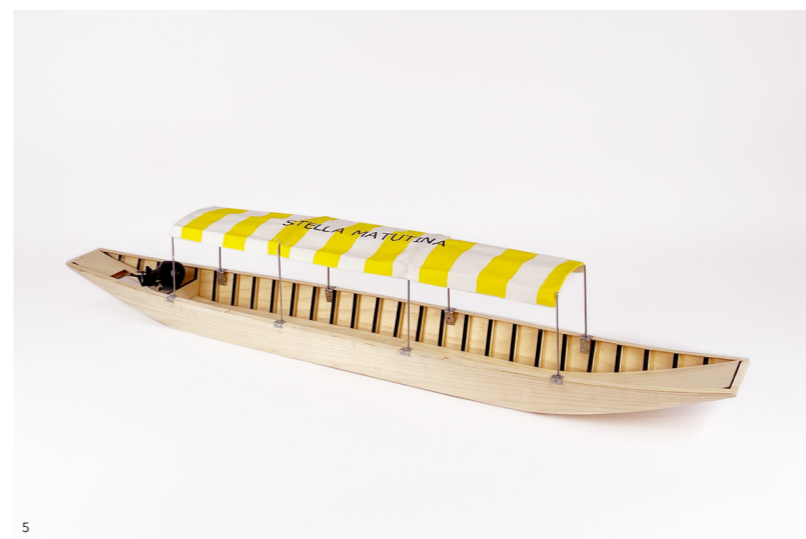
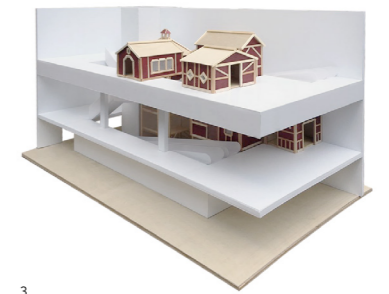

constructions

model building



1



2

- ¹ door handle made of Sika block with belt holder
- ² assembled hygiene version for operation with the foot, Sika and limewood
- ³ skull-shaped door knob made of TecClay
- ⁴ concept sketches for a generic tattoo studio or rocker club door handle kit
- ⁵ whole set of the designed models, built from different materials



3

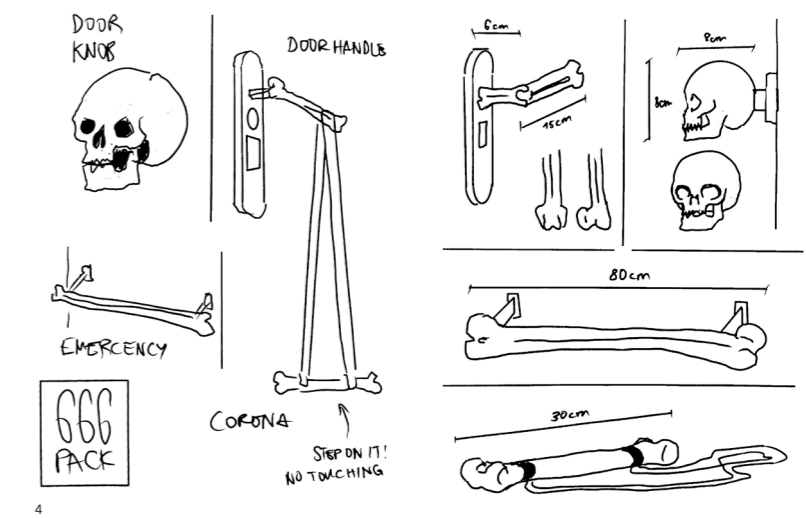

4



5

digital fabrication

3D modeling
rendering

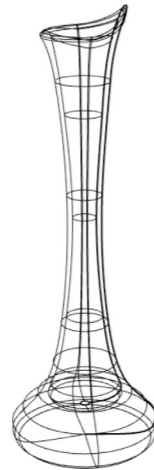
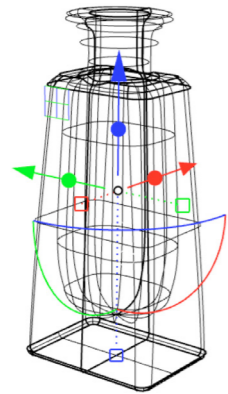

specifications

year

2021-2023

description

a selection of 3D works and rendering from my past years

work

3D construction and modeling in Rhino, Blender or 4D Cinema, texturing, lighting, rendering

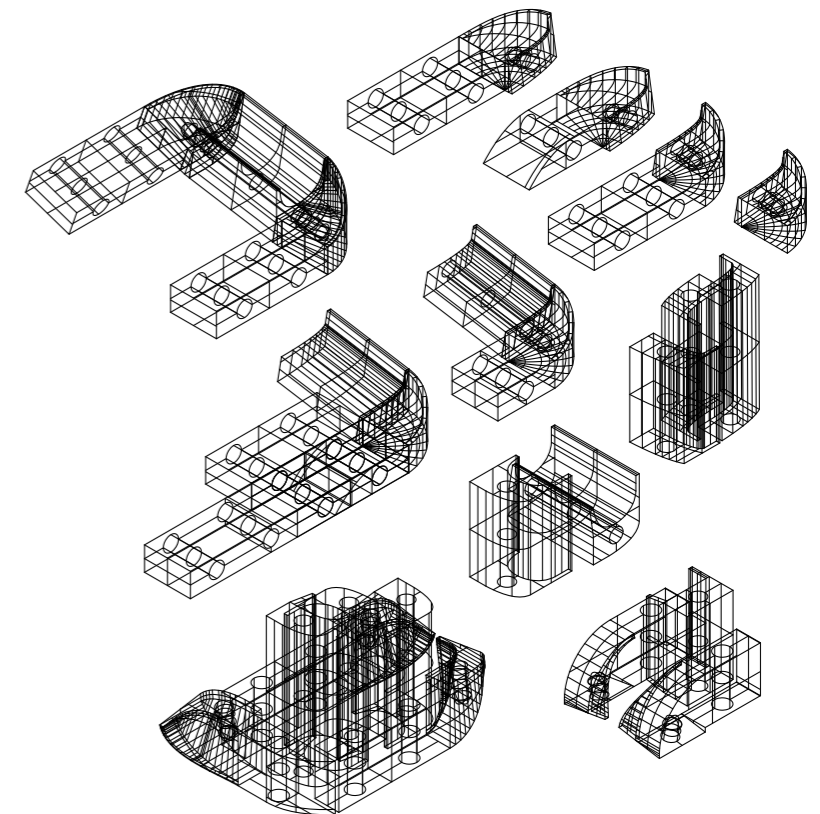
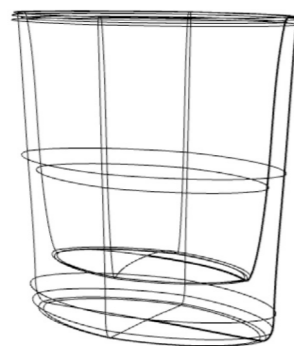
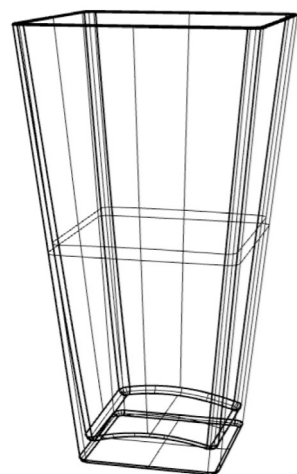
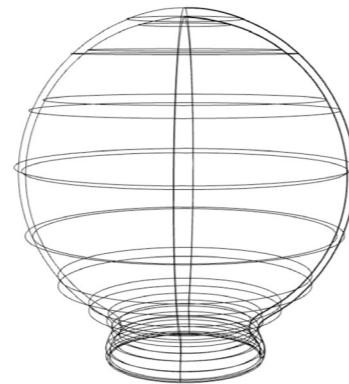
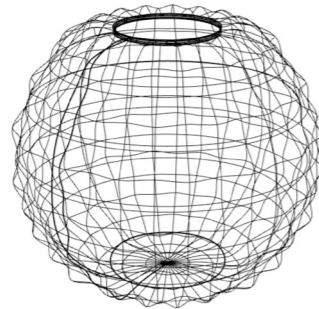
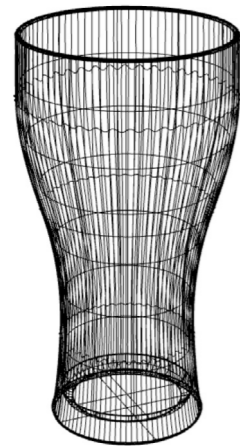

¹ exercising 3D modeling with different glass types
² 3D models for 3D printed parts

2

digital fabrication

3D modeling rendering

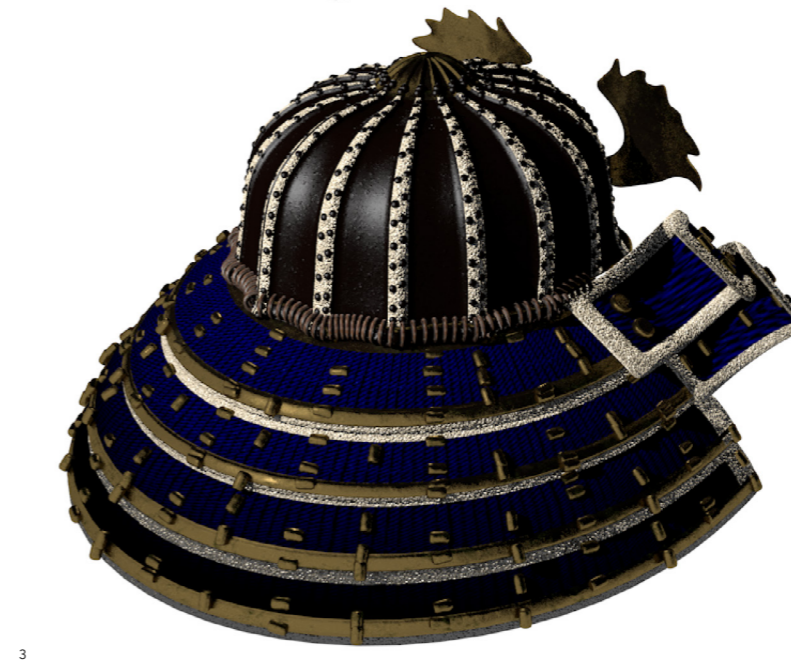
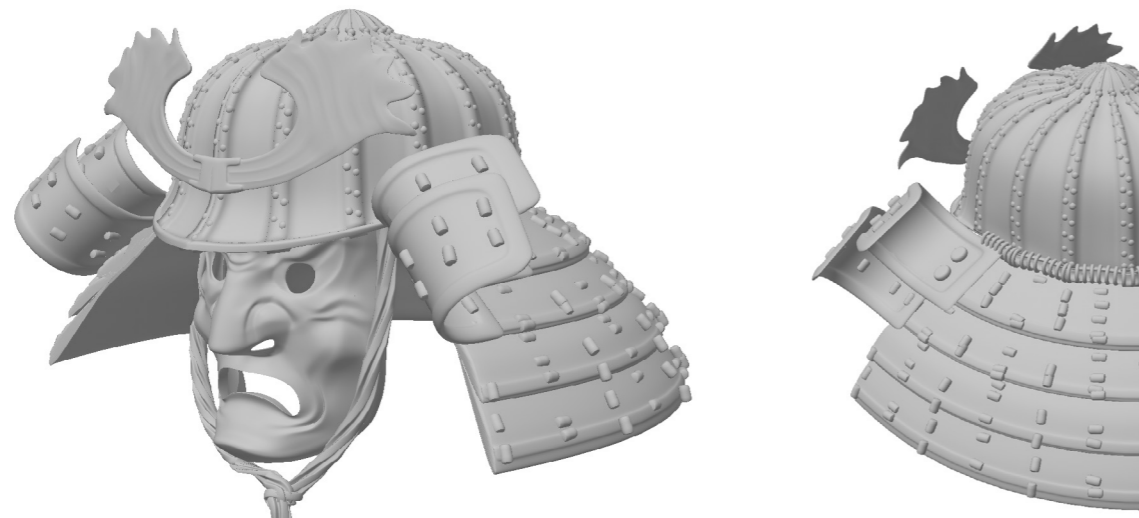
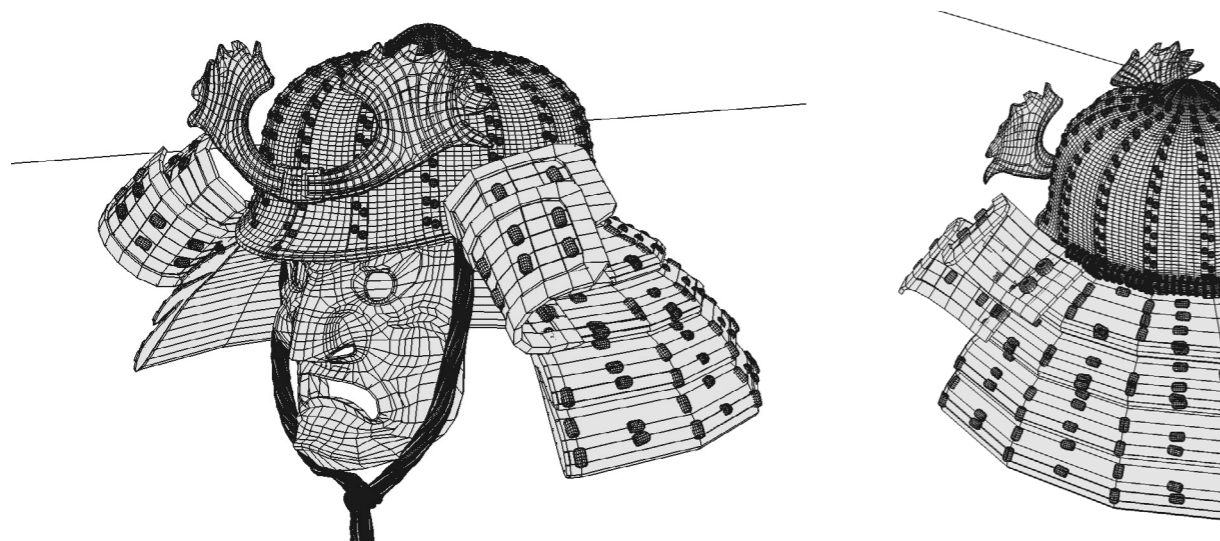

- ¹ samurai mask 3D modeled from reference picture in 4D Cinema, mesh, textured and lighted
- ² samurai mask and helmet, mesh and clay model, front and back
- ³ samurai head gear assembly rendered with lighting on neutral background
- ⁴ assembly rendered with lighting on dark background
- ⁵ rendered skin close up of attempt to create ray skin texture

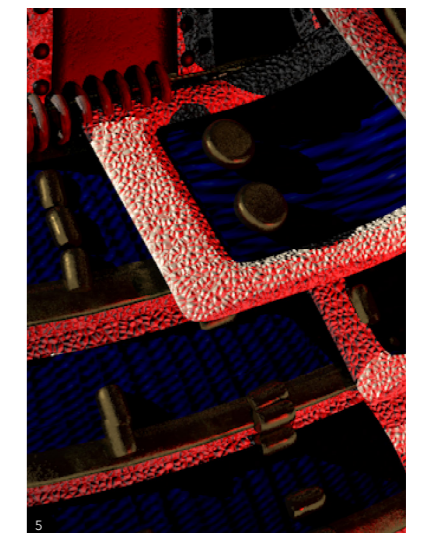
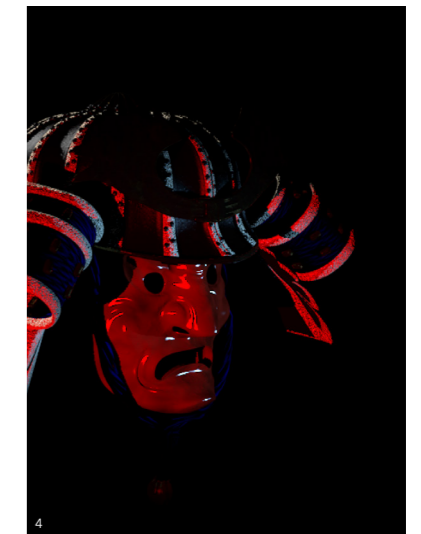

digital fabrication

3D modeling
rendering

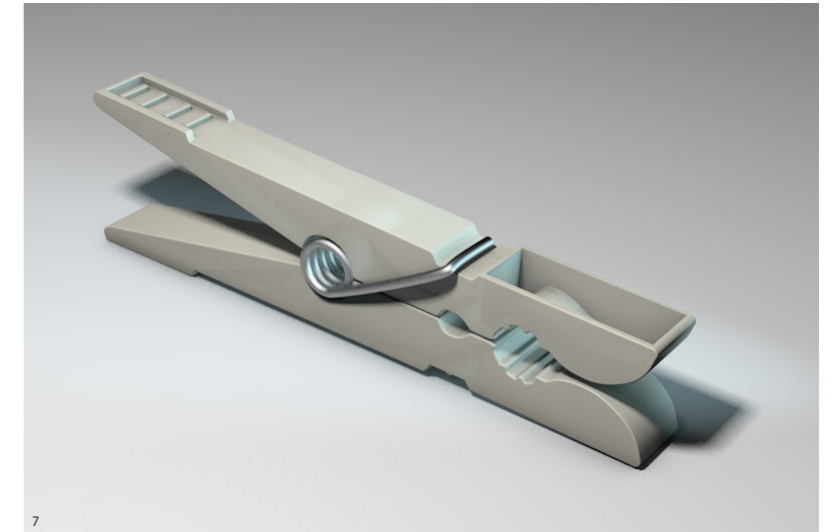
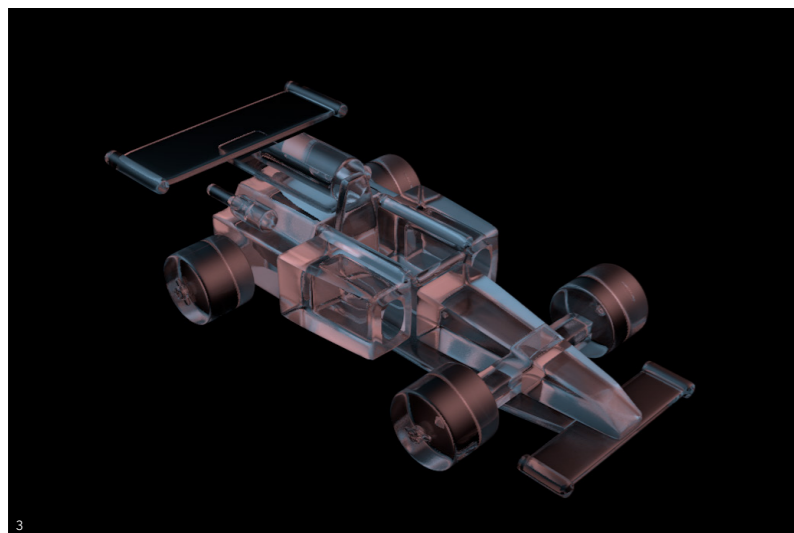
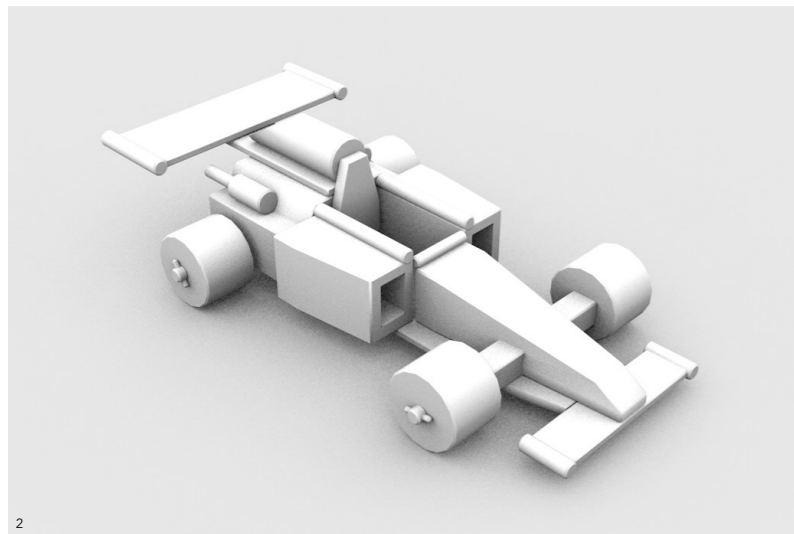
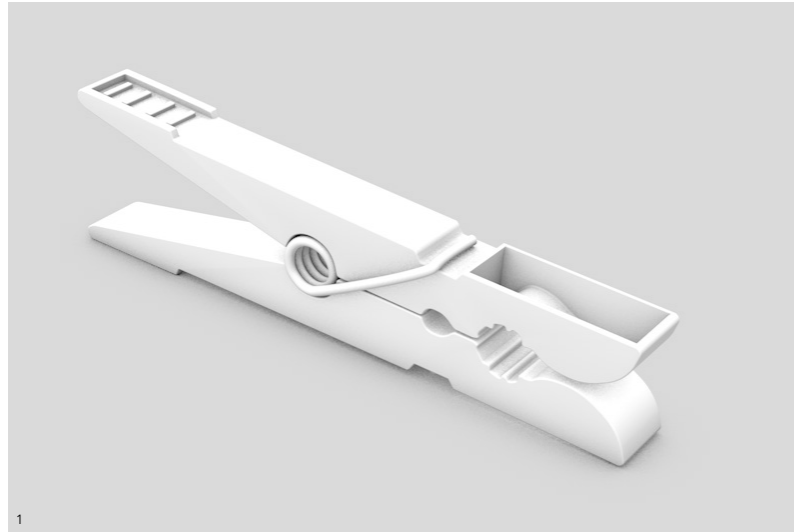

- ¹ laundry clip clay model, Cinema 4D
- ² toy race car clay model
- ³ toy race car glass rendering with two light sources
- ⁴ steel drinking bottle clay model
- ⁵ steel drinking bottle rendering light
- ⁶ steel drinking bottle rendering night
- ⁷ laundry clip rendering
- ⁸ rendering of the steel drinking bottle opened



interdisciplinary

DOG\$\$



mini applications code experiments

specifications

year 2022
code HTML, CSS, Javascript, JSON

description

data visualization of my expenses over the period of one month in the form of hot dogs and a dot following you around

work

conceptualising ideas, design, and development of the mini-sites

black

red

small



MADE WITH PS_JS

blue

pink



click or scan me

graphics

graphic designs
printing
illustrations

specifications

year 2011-2023
print tech silkscreen,
offset, Riso, digital
binding tech. glued, stiched,
folded

description

selection of graphics, illustrations,
prints and editorials that I
have done over the years

work

conceptualising ideas, design,
and development of the mini-
sites

¹ visual manual about Riso printing with its flaws and beauties, printed on Riso
printer, folded

² backprint design, showing different coloration variants of the same motif

³ printed version, with frontprint explaining resolutions, layering, accuracy
between layers

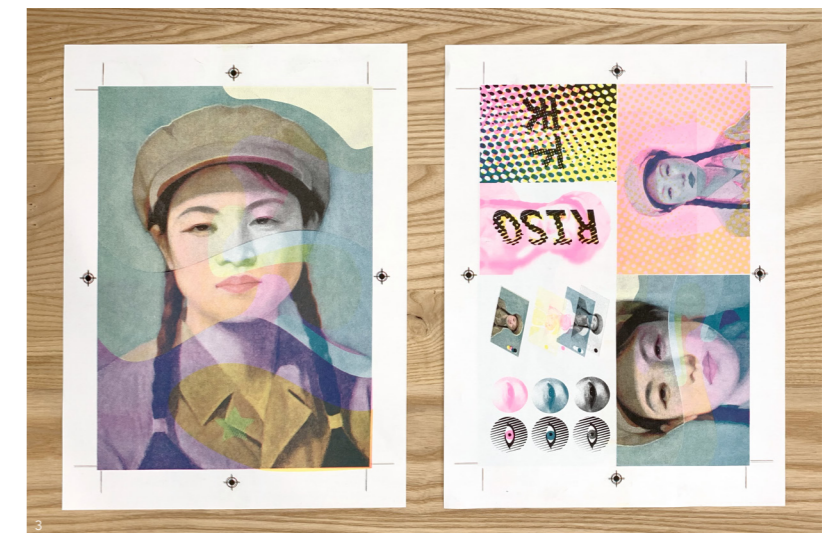

graphics

graphic designs
printing
illustrations



- ¹ visual manual about offset printing, 2 color offset print , folded
- ² back and front visually explaining offset technique on the same motif
- ³ working the semi automatic offset printing machine
- ⁴ examples of bound spines
- ⁵ zine with multi-layered cover
- ⁶ printed version of my 2021 portfolio, various cover iterations



graphics

graphic designs
printing
illustrations

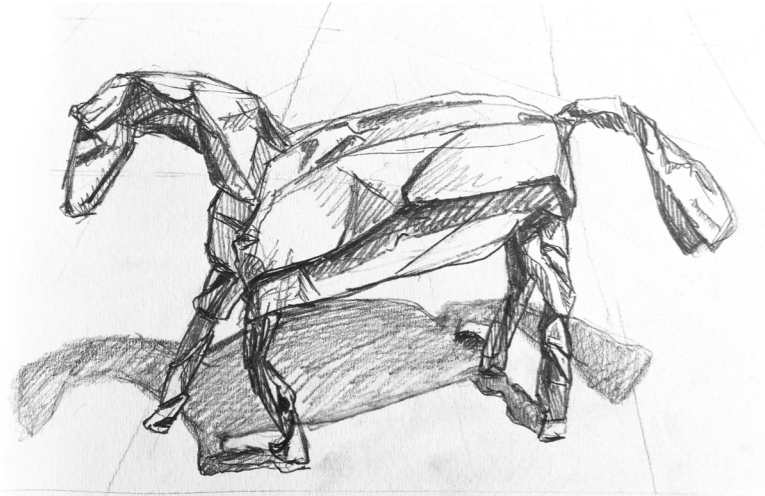

- 1 pencil drawing paper horse
- 2 pencil drawing same horse
- 3 unfinished pencil drawing of chisa katana from collection
- 4 pencil drawing of bottle with paper stuck in it
- 5 paper drawing of katana and chisa katana
- 6 pencil drawing of rubber glove
- 7 pencil drawing of knife
- 8 pencil drawing of wood artefact from ethnological museum

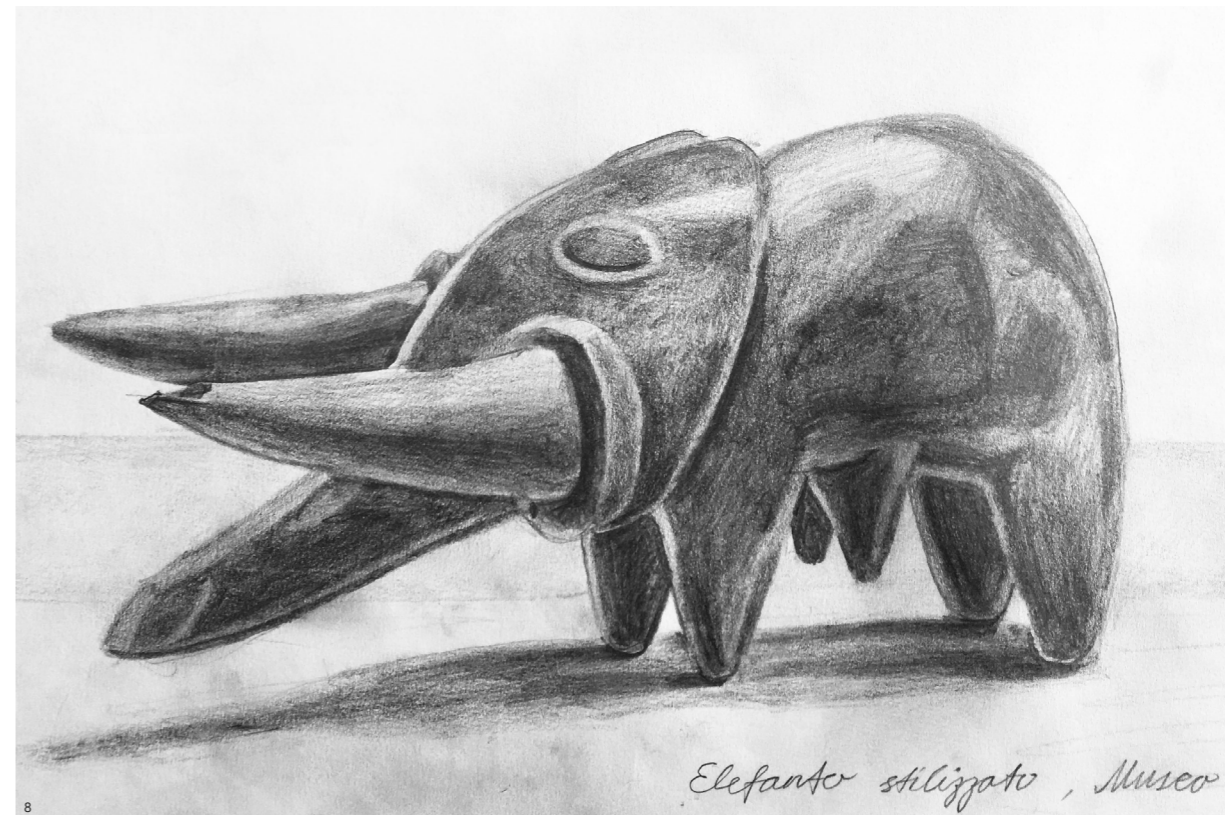
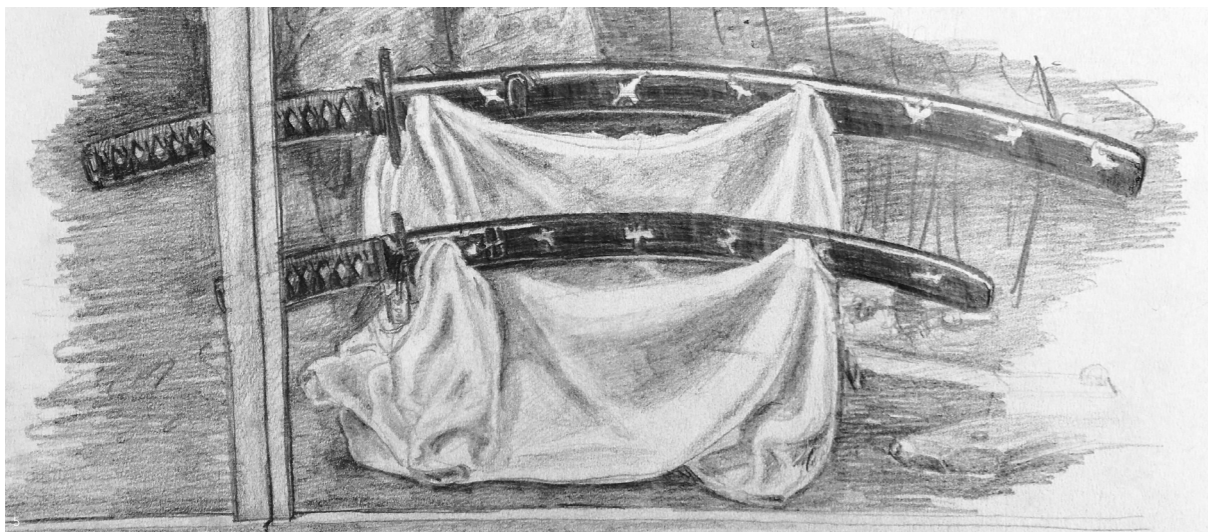
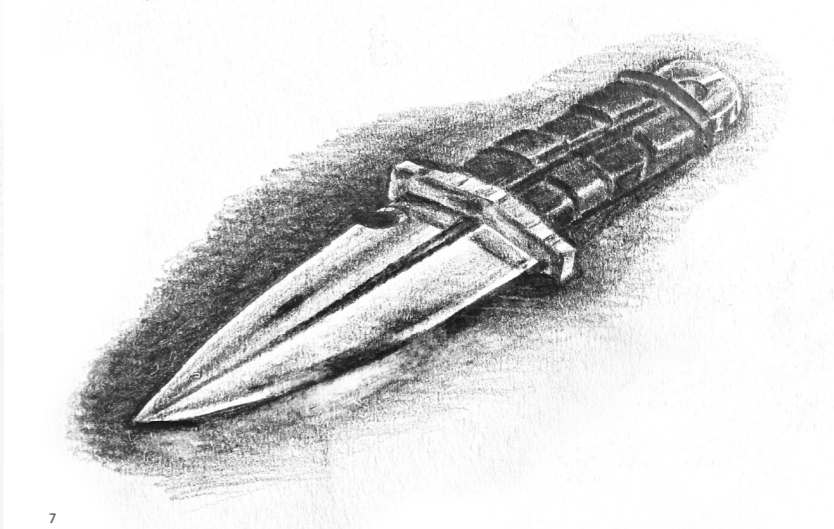
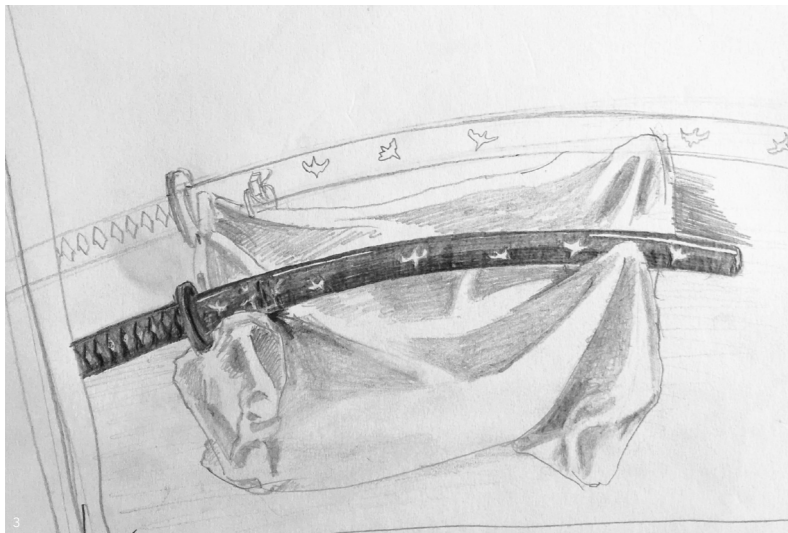



graphics

graphic designs
printing
illustrations

- 1 illustration of random stuff in the atmosphere
- 2 stylized illustration of shake nigiri with nori wrap
- 3 illustration of shake nigiri
- 4 study of bird in museum
- 5 study of snakes in museum

